

Technical Sheet No. 12

String course

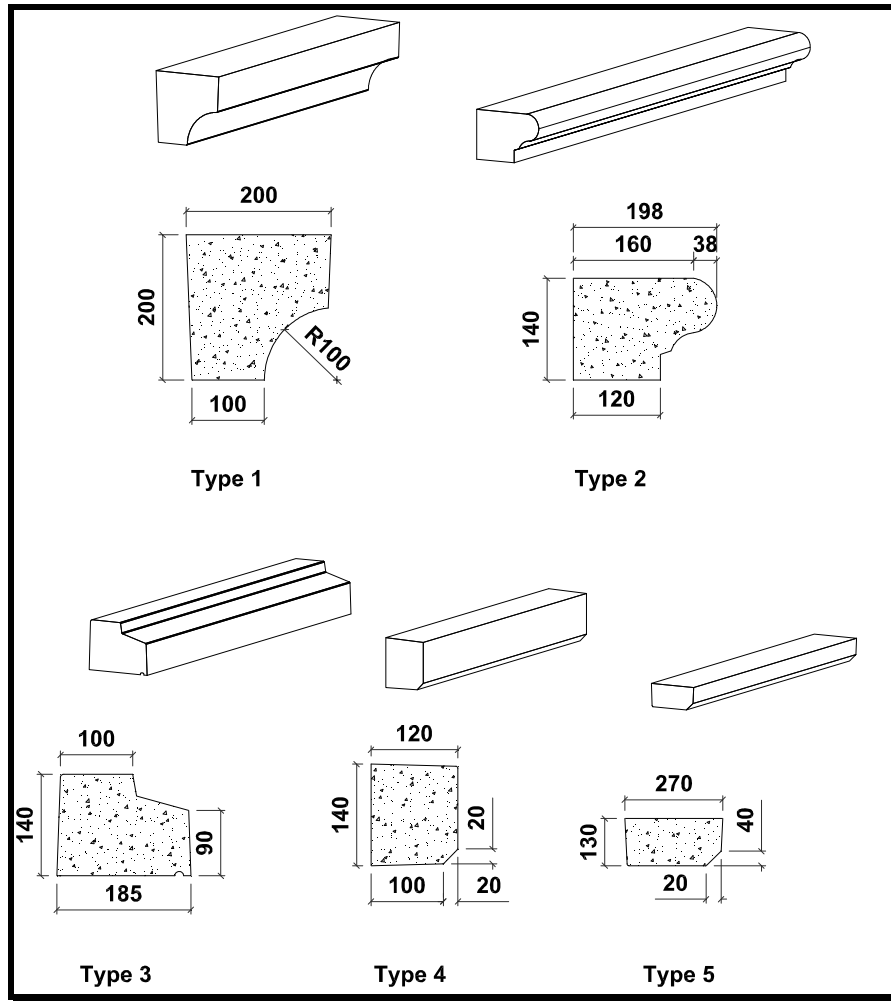

String Course	Length	Weight
Type 1	1000mm	78kg
Type 2	1500mm	84Kg
Type 3	1125mm	61Kg
Type 4	900mm	36Kg
Type 5	900mm	19Kg

Precast string course is an ornamental feature that projects slightly across the facade, between the stories of a building. They are made to order in plain grey, reconstituted sandstone or reconstituted granite.

Please contact our sales office on 028 3833 2807 for information, advice or quotation.

Material Data	
Concrete Grade	C35
Reinforcement	High yield 460N/mm ² (For handling only)
Cover	25mm min.